

G. J. FORREY.  
SCREW CUTTING MACHINE.

No. 459,277.

Patented Sept. 8, 1891.

*Fig. 1.*

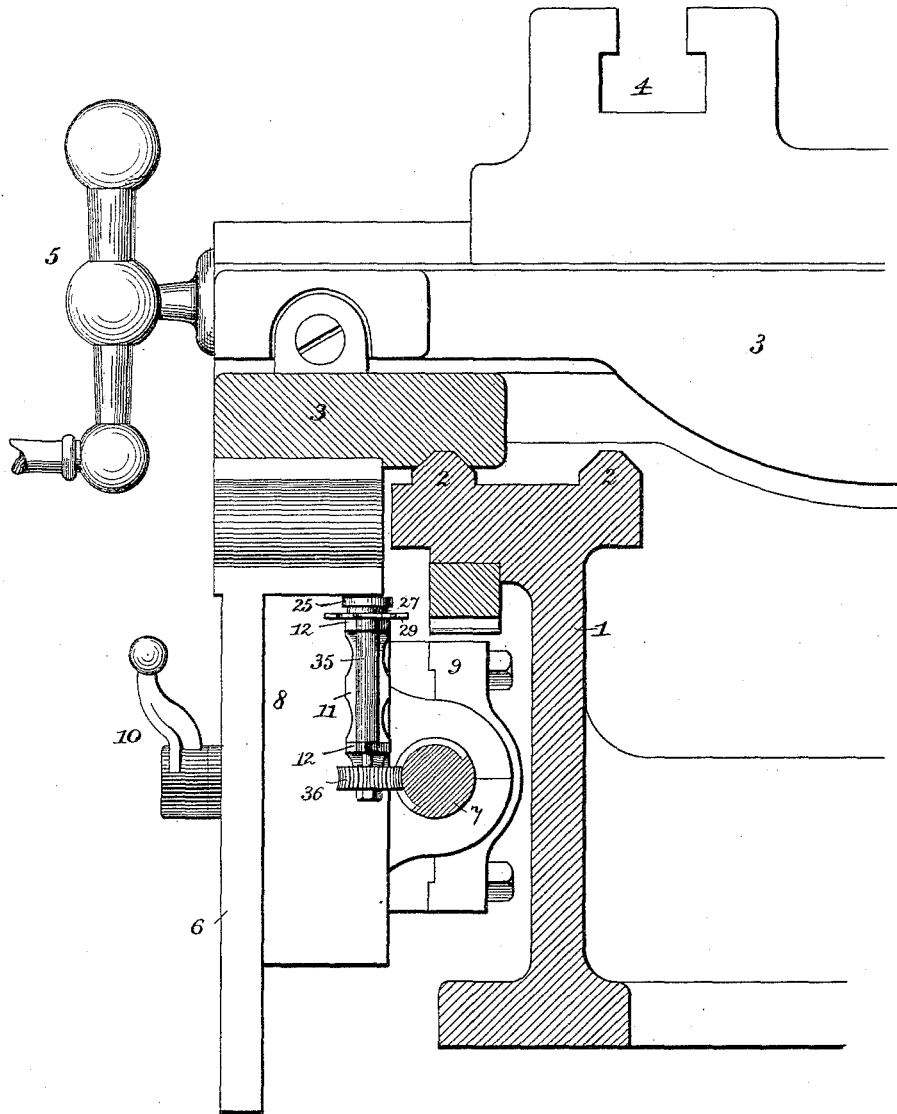

Witnesses

Inventor

*Chas. H. Curand*

*George J. Forrey*

*Wm. Bagger*

By his Attorneys,

*C. Snow & Co.*

G. J. FORREY.  
SCREW CUTTING MACHINE.

No. 459,277.

Patented Sept. 8, 1891.

Fig. 3.

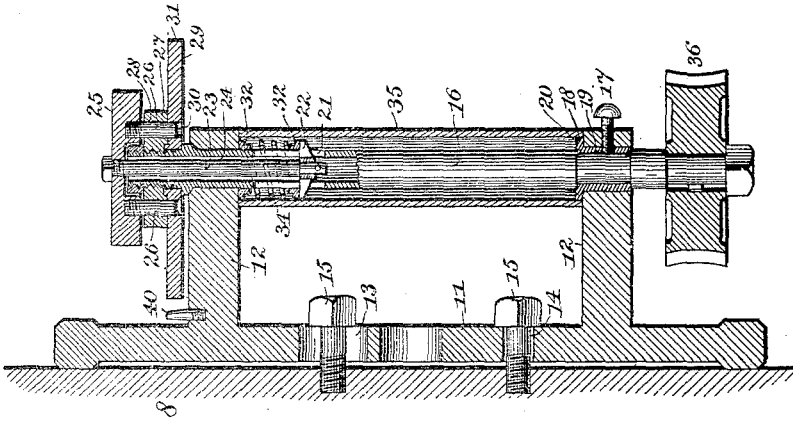
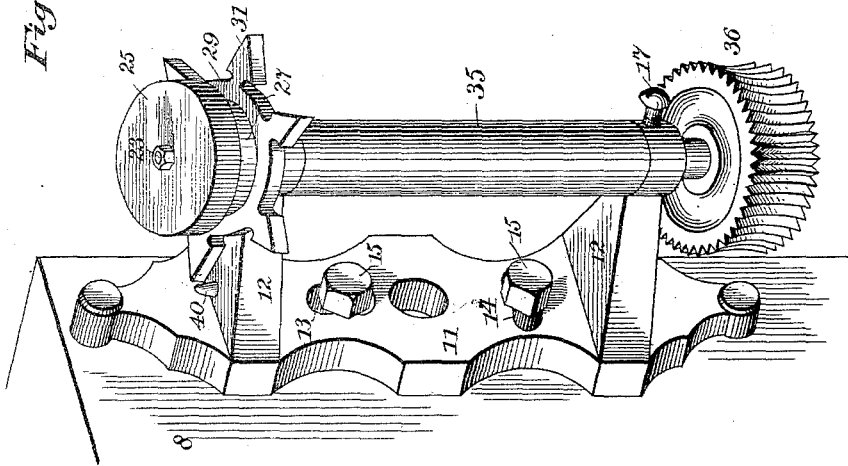

Fig. 2.



Witnesses

Inventor

Chas. H. Ourand

George J. Forrey,

Wm. Bagger

By his Attorneys,

Chas. Snow & Co.

G. J. FORREY.  
SCREW CUTTING MACHINE.

No. 459,277.

Patented Sept. 8, 1891.

Fig. 4.

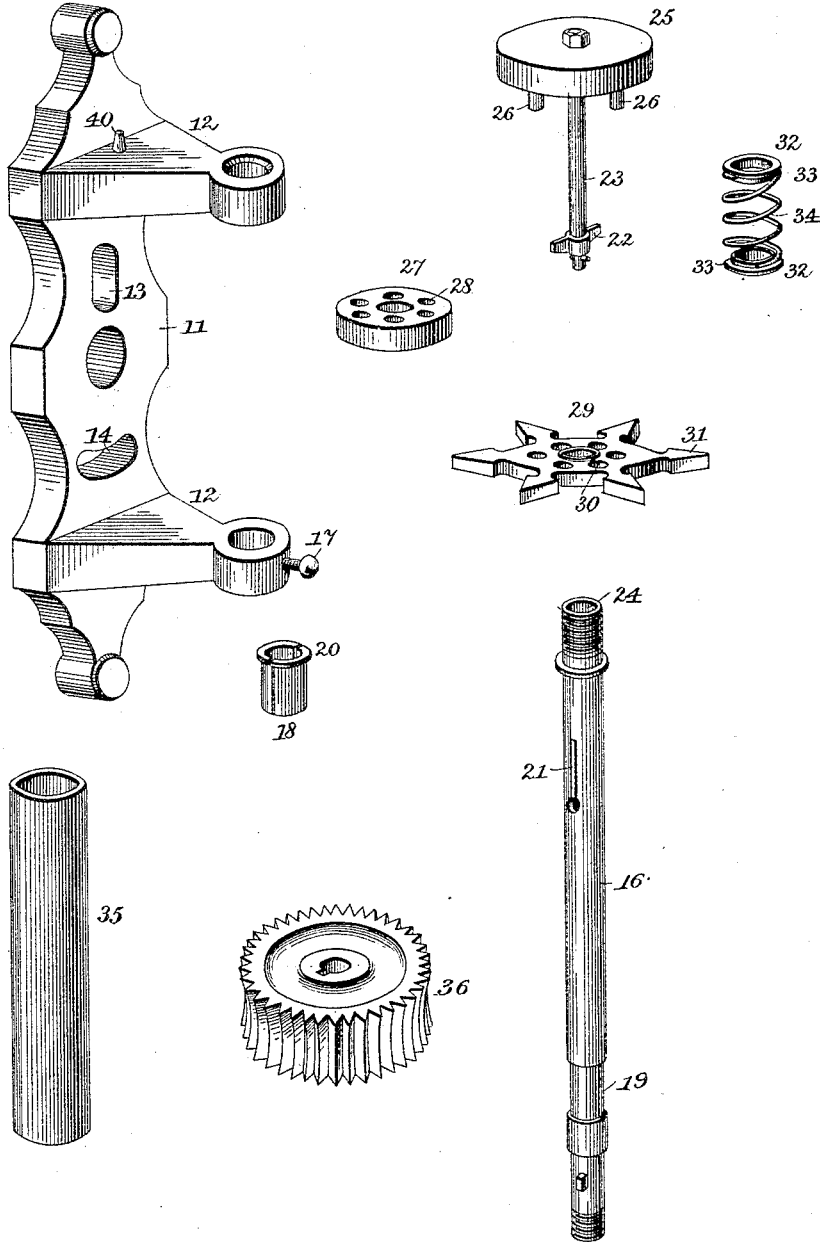

Witnesses

Chas. H. Ourand

Wm. Bagger

Inventor

George J. Forrey

By his Attorneys,

C. Snow & Co.

# UNITED STATES PATENT OFFICE.

GEORGE JONNATHAN FORREY, OF CARLISLE, PENNSYLVANIA.

## SCREW-CUTTING MACHINE.

SPECIFICATION forming part of Letters Patent No. 459,277, dated September 8, 1891.

Application filed April 30, 1891. Serial No. 391,113. (No model.)

*To all whom it may concern:*

Be it known that I, GEORGE JONNATHAN FORREY, a citizen of the United States, residing at Carlisle, in the county of Cumberland and State of Pennsylvania, have invented a new and useful Screw-Cutting Machine, of which the following is a specification.

This invention relates to an improved attachment for screw-cutting lathes; and it has for its object to enable the lock-nut of the tool-carriage to be closed upon the lead-screw at exactly the right time to cause the cutting-tool to register with the thread of the screw which is being cut, whether the thread be even or uneven with relation to the pitch of the lead-screw; also, to enable the tool to be properly set when more than one thread is being cut, thus enabling the several threads to be alternately or successively operated upon, which could not otherwise conveniently be done.

With these ends in view the invention consists in the improved construction, arrangement, and combination of parts, which will be hereinafter fully described, and particularly pointed out in the claims.

In the drawings hereto annexed, Figure 1 is a sectional view taken vertically and transversely through the bed of a screw-cutting lathe and showing in side elevation the tool-carriage to which my invention has been applied. Fig. 2 is a perspective view showing one side of the tool-carriage with my improved attachment in position for operation. Fig. 3 is a sectional view taken vertically through my improved attachment. Fig. 4 is a detail view showing the several parts comprising my improved attachment separated from each other.

Like numerals of reference indicate like parts in all the figures.

1 designates the bed of the lathe, 2 2 the ways thereof, and 3 the tool-carriage mounted thereon. The tool-carriage is provided in the usual manner with the socket 4 for the tool-post and with the handle 5 of the screw for controlling the cross-feed.

6 designates the apron of the tool-carriage, which depends in front of the lead-screw 7. Said apron is provided on its inner side with the guides 8 for the halves of the lock-nut 9, which are operated in the usual manner by

the handle 10 to open or close upon the lead-screw as occasion may demand.

The parts thus far described are not necessarily of the construction shown in the annexed drawings, but have simply been shown to indicate well-known construction which is found in almost every screw-cutting machine of modern pattern.

Suitably secured to one side of the tool-carriage is a bracket which is composed of a base-plate 11, having laterally-extending arms 12 12, and which is provided at suitable distances above and below its center with slots 13 and 14, the former of which is vertical, while the latter is horizontal and slightly segmental with relation to the slot 13. These slots are for the reception of the bolts 15, by means of which the bracket is secured to the tool-carriage, and it will be readily seen that the lower end of the said bracket, owing to the horizontal slot 14, may be readily swung to or from the lead-screw. The object of this will be presently set forth.

The arms 12 are provided at their outer ends with bearings for a vertical shaft 16. The upper end of said shaft may be journaled directly in the upper bracket 12. The lower bracket 12 is provided with a set-screw 17, adapted to engage the divided bushing 18, which forms the bearing for the lower end of the shaft 16, which latter is provided with an annular groove 19, forming a seat for the said bushing. The latter is provided with an annular flange 20 at its upper end.

The shaft 16 is provided near its upper end with a vertical slot 21, in which is mounted the cross-piece or yoke 22, which extends at opposite sides of the shaft and in which is mounted the lower end of a spindle 23, the upper end of which extends through a vertical bore 24 in the upper end of the shaft 16. The upper end of the spindle 23 carries a disk 25, having downwardly-extending diametrically-opposite lugs 26. Upon the upper end of the shaft 16 is mounted a disk 27, which is provided with perforations 28, and an indicator-disk 29, having similar perforations 30, is mounted loosely upon the shaft 16 directly below the disk 27. The indicator-disk 29 is provided with radially-extending arms or pointers 31, registering with the perforations 30.

Upon the shaft 16, directly below the upper

arm 12 and above the yoke 22, are placed collars or washers 32, having annular flanges 33, between which is mounted a spiral spring 34, pressing downwardly against the yoke 22, and thus forcing the stem or spindle 23 with the disk 25, having the downwardly-extending lugs 26, in a downward direction and causing the said lugs to engage the perforations 28 and 30 in the disks 27 and 29, respectively, and thus locking the latter upon the shaft.

35 designates a sleeve or ferrule which surrounds the shaft 16 between the arms or bearings 12 12, said sleeve being mounted upon the flanges 33 of the washers 32 and upon the flange 20 of the bushing 18, thus protecting the mechanism of the device, while said sleeve itself is loose with relation to the shaft, and may be grasped even when the shaft rotates.

Securely mounted upon the lower end of the shaft 16 is a pinion 36, adapted to engage the lead-screw, and of course of the same pitch as the latter. It is to be observed that the indicator-disk 29 is to be provided with a number of arms or brackets which shall be equal to the multiple of the teeth of the pinion 36 of the pitch of the lead-screw. Thus when the latter is six threads to the inch and the pinion has thirty-six teeth the indicator-plate will have six arms or pointers.

The ordinary operation of a screw-cutting lathe is well understood and will require to be only briefly described. After properly adjusting the cutting-tool the halves of the lock-nut are closed upon the lead-screw, when by the rotation of the latter the tool-carriage will be caused to travel the length of the lathe-bed or until the end of the screw that is to be cut is reached, the thread being partially cut on the screw by the action of the cutting-tool. The lock-nut is then opened and the carriage is moved by hand back to the starting-point, at which the tool is slightly fed forward to engage the thread of the screw. The lock-nut is closed and the operation repeated. This method of operation will answer when the pitch of the screw that is to be cut is the same as that of the lead-screw or the multiple thereof. When, however, a screw is to be cut with threads of a pitch that is uneven with relation to that of the lead-screw, the difficulty becomes increased, for the reason that it becomes exceedingly difficult to cause the cutting-tool to engage the thread of the screw at exactly the right point. It has been customary to reverse the direction of rotation of the lead-screw, and thus feed the carriage back along the latter, which obviously would accomplish the desired result, but in a very slow manner and at a great loss of time. By my invention it becomes possible to restore the carriage to the starting-point by hand, and also to cause the cutting-tool to engage the screw-thread which is being cut at exactly the right point without danger of making any mistake or of injuring the work. To accomplish this I proceed as follows: When starting to work, the position of the indicator-

disk is carefully noted with relation to a lug or pointer 40 upon the upper side of the upper bracket 12. While the lock-nut is closed upon the lead-screw and the tool-carriage is traveling along the bed of the lathe, a shaft 16 remains stationary, as will be readily understood, the pinion or worm wheel at the lower end of said shaft traveling along in engagement with the lead-screw. When the end of the work is reached and the lock-nut is opened, the shaft 16, with its attachments, begins to rotate. The tool-carriage is now moved back to the starting-point by hand, and it now becomes necessary to so adjust the carriage as to cause the tool to properly engage the thread that is being cut. This, then, is accomplished by first slightly raising the disk 25 until the lugs 26 of the latter by slightly turning the said disk may be rested upon the upper side of the disk 27. This operation unlocks the indicator-disk 29 from the shaft 16 and enables the said indicator-disk to be turned to the desired position—that is, to the position occupied by said disk at the original start. The disk 25 is then restored to lock the indicator-disk upon the shaft, the cutting-tool is fed forward, the lock-nut closed, and the operation of cutting is repeated.

It is obvious that by this invention uneven threads of any desired pitch with relation to the pitch of the lead-screw may be cut, suitable well-known mechanism being employed to regulate the speed of the feed with relation to the rotation of the lead-screw. It is also evident that this invention will be found useful when screws are to be cut having two or more threads.

When it is desired to use the machine without my improved attachment, it is not necessary to remove the same, as by reason of the bolt 15 the lower end of the bracket 11 may be swung away from the lead-screw, thus throwing the pinion or worm-gear 46 out of engagement with the latter.

Having described my invention, what I claim is—

1. In a screw-cutting machine, the combination of the tool-carriage, the bracket secured to the same and having laterally-extending arms, the shaft journaled in said arms and provided at its lower end with a pinion or worm-gear engaging the lead-screw and having at its upper end an indicator-disk with radially-extending arms, a pointer or indicator upon the upper side of the upper bearing-arm, and means, substantially as described, for locking the indicator-disk adjustably upon the shaft, substantially as set forth.

2. In a screw-cutting machine, the combination, with the tool-carriage, of the bracket secured adjustably to one side thereof and having laterally-extending arms, the upper one of which has an upwardly-extending lug or pointer, of the shaft journaled in said arms and having at its lower end a worm-

gear meshing with the lead-screw and at its upper end a loosely-mounted indicator-disk provided with vertical perforations and the radially-extending arms, the disk mounted upon the vertical shaft above said indicator-disk and having perforations registering with the perforations in said indicator-disk, a spindle mounted slidingly in a bore or recess at the upper end of the vertical shaft and carrying a disk having downwardly-extending lugs adapted to engage the perforations in the indicator-disk and in the disk above the latter, and a spring arranged to force said spindle in a downward direction, substantially as set forth.

3. In a device of the class described, the combination of the vertical shaft having the worm-gear adapted to engage the lead-screw of a screw-cutting machine and provided at its upper end with a transverse slot and with a vertical bore or recess, a disk mounted at the upper end of said shaft and having vertical perforations, the indicator-disk mounted loosely below said disk and having perforations registering with the perforations in the latter and the radially-extending arms or indicators, a yoke mounted in the transverse slot at the upper end of the vertical shaft, a spindle journaled in said yoke, extending through the vertical bore at the upper end of the shaft and carrying a disk provided with downwardly-extending lugs to engage the perforations in the indicator-disk and in the disk above the latter, and a spring arranged to force said yoke with its attached spindle in a downward direction, substantially as set forth.

4. The combination of the shaft having at its upper end a vertical bore and a transverse slot, a yoke seated in the latter, a spindle mounted in said yoke, extending upwardly through the bore and carrying the locking-disk provided with downwardly-extending lugs, a bearing for the upper end of the shaft, annularly-flanged washers mounted in the shaft below the upper bearing and above the yoke, and the spring coiled around the shaft

and forcing the yoke with the spindle carrying the locking-disk in a downward direction, substantially as set forth.

5. The combination of the bracket having laterally-extending arms, the lower one of which is provided with a set-screw engaging a divided bushing, the shaft journaled in said bushing and in a perforation or bearing in the upper arm, said shaft being provided with a pinion or worm-gear at its lower end and at its upper end with a transverse slot and a vertical bore, a yoke mounted on said slot, a spindle journaled in said yoke and extending upwardly through the bore of the shaft, the indicator-disk mounted loosely near the upper end of the shaft, a disk mounted securely at the upper end of the same, the locking-disk mounted on the upper end of the spindle and having downwardly-extending lugs adapted to engage perforations in the indicator-disk and in the disk above the latter, the flanged washers arranged upon the shaft above the yoke and below the upper bearing, the spring coiled upon the shaft between said flanged washers, and the sleeve or ferrule surrounding the shaft between its bearings, said sleeve being supported upon the flanges of the washers and of the bushing in the lower bearing-arm, substantially as and for the purpose set forth.

6. In a screw-cutting machine, the combination of the tool-carriage, the shaft journaled thereon and provided at its lower end with a pinion or worm-gear engaging the lead-screw and having at its upper end an indicator-disk, and means, substantially as described, for locking the indicator-disk adjustably upon the shaft.

In testimony that I claim the foregoing as my own I have hereto affixed my signature in presence of two witnesses.

GEORGE JONNATHAN FORREY.

Witnesses:

M. T. FITZPATRICK,  
J. M. ALLEN.